

Overview

Signature Series Model SIGA-HFS and SIGA-HRS Intelligent Heat Detectors gather analog information from their fixed temperature and/or rate-of-rise heat sensing elements and converts it into digital signals. The detector's on-board microprocessor measures and analyzes these signals. It compares the information to historical readings and time patterns to make an alarm decision. Digital filters remove signal patterns that are not typical of fires. Unwanted alarms are virtually eliminated.

The microprocessor in each detector provides four additional benefits - Self-diagnostics and History Log, Automatic Device Mapping, Stand-alone Operation and Fast, Stable Communication.

Standard Features

Note: Some features described here may not be supported by all control systems. Check your control panel's Installation and Operation Guide for details.

- 70 foot (21.3 meter) spacing
- 15° F (9° C)/min rate-of-rise/135° F (57° C) ft. and 135° F (57° C) fixed temperature type
- Intelligent detector c/w integral microprocessor
- Non-volatile memory
- Automatic device mapping
- Electronic addressing
- Identification of defective detectors
- Twin RED/GREEN status LEDs
- Standard, relay, fault isolator, and audible mounting bases
- Designed and manufactured to ISO 9001 standards

Intelligent Heat Detectors

SIGA-HFS & SIGA-HRS



Signature Series Overview

Self-diagnostics and History Log - Each Signature Series detector constantly runs self-checks to provide important maintenance information. The results of the self-check are automatically updated and permanently stored in the detector's non-volatile memory. This information is accessible for review any time at the control panel, PC, or by using the SIGA-PRO Signature Program/Service Tool.

In the unlikely event that an unwanted alarm does take place, the control panel's history file can be called up to help isolate the problem and prevent it from happening again.

Automatic Device Mapping - The loop controller learns where each device's serial number address is installed relative to other devices on the circuit. This mapping feature provides supervision of each device's installed location to prevent a detector from being reinstalled (after cleaning etc.) in a different location from where it was originally. The history log for the detector remains relevant and intact regardless of its new location.

The Signature Series Data Entry Program also uses the mapping feature. With interactive menus and graphic support, the wired circuits between each device can be examined. Layout or "as-built" drawing information showing wire branches (T-taps), device types and their address are stored on disk for printing hard copy. This takes the mystery out of the installation. The preparation of as-built drawings is fast and efficient.

Stand-alone Operation - A decentralized alarm decision by the detector is guaranteed. On-board intelligence permits the detector to operate in stand-alone mode. If loop controller CPU communications fail for more than four seconds, all devices on that circuit go into stand-alone mode. The circuit acts like a conventional alarm receiving circuit. Each detector on the circuit continues to collect and analyze information from its surroundings. Both the SIGA-HRS and SIGA-HFS detectors alarm if the ambient temperature increases to 135°F (57°C) or for the SIGA-HRS only, the temperature increases at a rate exceeding 15°F (9°C)/minute. If the detector is mounted to a relay base, the relay operates. Similarly, if it is mounted to an audible base, the on-board horn sounds.

Fast Stable Communication - On-board intelligence means less information needs to be sent between the detector and the loop controller. Other than regular supervisory polling response, the detector only needs to communicate with the control panel when it has something new to report. This provides very fast control panel response time and allows a lower baud rate (speed) to be used for communication on the circuit. The lower baud rate offers several advantages including:

- less sensitivity to circuit wire characteristics
- less sensitivity to noise glitches on the cable
- less emitted noise from the data wiring
- twisted or shielded wiring is not required

Electronic Addressing - The loop controller electronically addresses each detector, saving valuable time during system commissioning. Setting complicated switches or dials is not required. Each detector has its own unique serial number stored in its on-board memory. The loop controller identifies each device on the circuit and assigns a "soft" address to that device's serial number. If desired, detectors can be addressed using the SIGA-PRO Signature Program/Service Tool.

Installation Spacing - The SIGA-HFS (fixed temperature) and the SIGA-HRS (fixed temperature/rate-of-rise combination) intelligent heat detectors are rated for installation at up to 70 foot (21.3 meter) spacing. These detectors may be installed in rooms with ambient temperatures up to 100°F (38°C).

Status LEDs - Twin LEDs are visible from any direction. A flashing GREEN LED shows normal system polling from the loop controller. A flashing RED LED means the detector is in alarm state. Both LEDs on steady shows alarm state - stand-alone mode. Normal GREEN LED activity is not distracting to building occupants, but can be quickly spotted by a maintenance technician.

Quality and Reliability - GE Security detectors are manufactured in North America to strict international ISO 9001 standards. All electronics utilize surface mount technology (SMT) for smaller size and greater immunity to RF noise. A conformal coating is used for humidity and corrosion resistance. All critical contacts are gold plated.

Installation

Signature Series detectors mount to North American 1-gang boxes, 3-1/2 inch or 4 inch octagon boxes, and to 4 inch square electrical boxes 1-1/2 inches (38 mm) deep. They mount to European BESA and 1-gang boxes with 60.3 mm fixing centers.

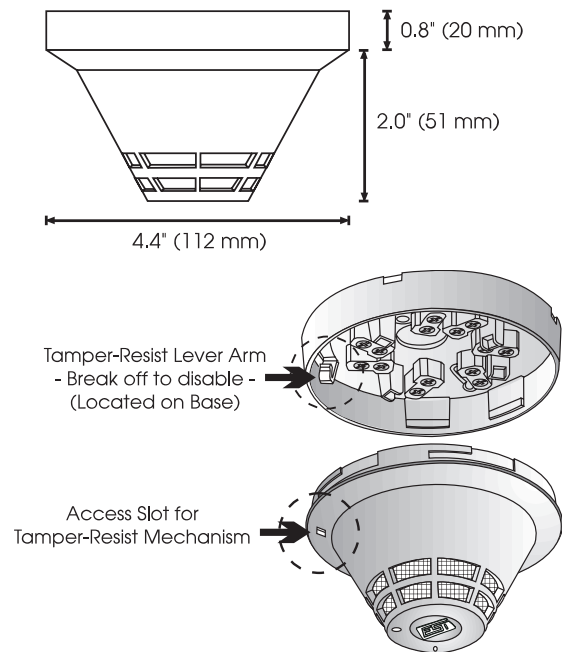

Application

The table below shows six standard test fires used to rate the sensitivity of smoke and heat detectors. The table indicates that no single sensing element is suited for all test fires.

GE Security recommends that this detector be installed according to latest recognized edition of national and local fire alarm codes.

Test Fire	SIGA-IS Ion	SIGA-PS Photo	SIGA-HRS and SIGA-HFS Rate-of-Rise/Fixed Temp.	SIGA-PHS Photo Heat 3D	SIGA-IPHS Ion/Photo/Heat 4D
Open Wood	optimum	unsuitable	optimum	very suitable	optimum
Wood Pyrolysis	suitable	optimum	unsuitable	optimum	optimum
Smouldering Cotton	very suitable	optimum	unsuitable	optimum	optimum
Poly Urethane Foam	very suitable	very suitable	suitable	very suitable	optimum
n-Heptane	optimum	very suitable	very suitable	optimum	optimum
Liquid Fire without Smoke	unsuitable	unsuitable	optimum	very suitable	very suitable

Typical Wiring

The detector mounting bases will accept #18 AWG (0.75mm²), #16 (1.0mm²), #14 AWG (1.5mm²), and #12 AWG (2.5mm²) wire sizes.

Note: Sizes #16 AWG (1.0mm²) and #18 AWG (0.75mm²) are preferred for ease of installation. See Signature Loop Controller catalog sheet for detailed wiring requirement specifications.

Standard Detector Base, SIGA-SB, SIGA-SB4

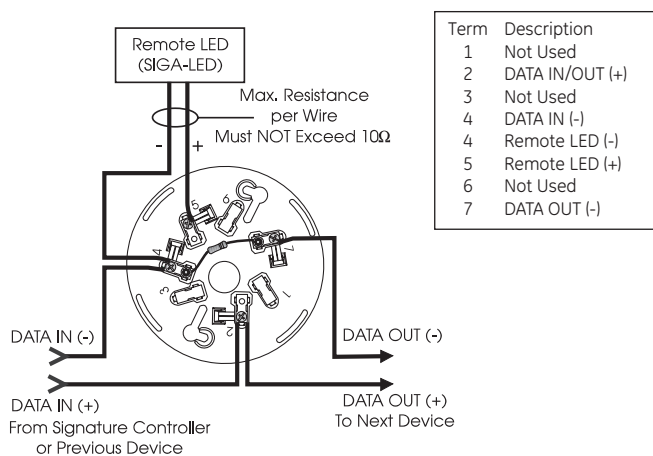

Relay Detector Base, SIGA-RB, SIGA-RB4

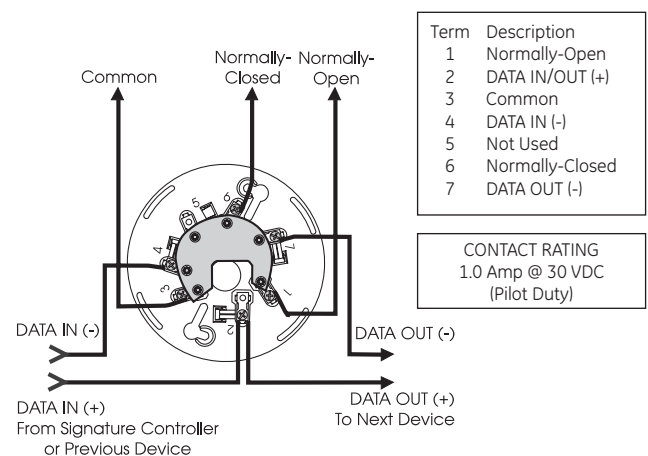

Isolator Detector Base, SIGA-IB, SIGA-IB4

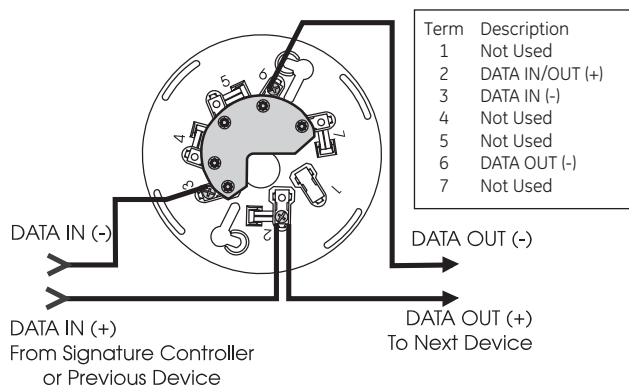

Audible Detector Base, SIGA-AB4G

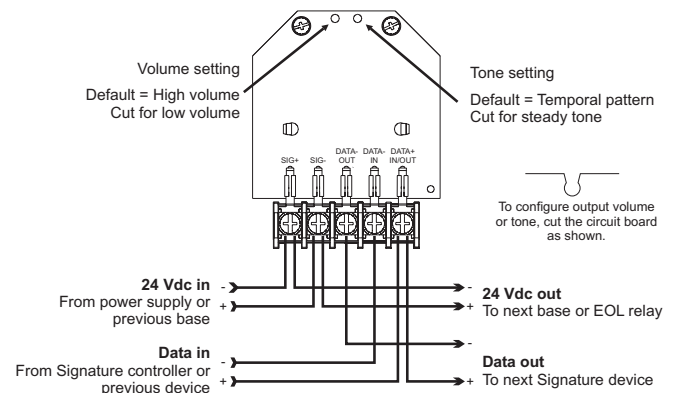

Accessories

All detector mounting bases have wiring terminals that are accessible from the “room-side” after mounting the base to the electrical box. The bases mount to North American 1-gang boxes and to 3½ inch or 4 inch octagon boxes, 1½ inches (38 mm) deep. They also mount to European BESA and 1-gang boxes with 60.3 mm fixing centers. The SIGA-SB4, SIGA-RB4, and SIGA-IB4 mount to North American four inch square electrical boxes in addition to the above boxes. They include the SIGA-TS4 Trim Skirt which is used to cover the “mounting ears” on the base. The SIGA-AB4G mounts to a 4” square box only.

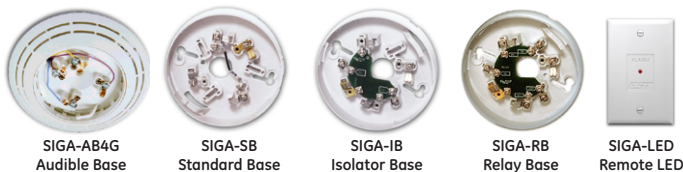

Standard Base SIGA-SB, SIGA-SB4 - This is the basic mounting base for GE Security Signature Series detectors. The SIGA-LED Remote LED is supported by the Standard Base.

Relay Base SIGA-RB, SIGA-RB4 - This base includes a relay. Normally open or closed operation is selected during installation. The dry contact is rated for 1 amp (pilot duty) @ 30 Vdc. The relay's position is supervised to avoid accidentally jarring it out of position. The SIGA-RB can be operated as a control relay if programmed to do so at the control panel (EST3 V. 2 only). The relay base does not support the SIGA-LED Remote LED.

Audible Base SIGA-AB4G - This base is designed for use where localized or group alarm signaling is required. When the detector senses an alarm condition, the audible base emits a local alarm signal. The optional SIGA-CRR Polarity Reversal Relay can be used for sounding to other audible bases on the same 24 Vdc circuit.

Relay and Audible Bases operate as follows:

- at system power-up or reset, the relay is de-energized
- when a detector is installed in the base with the power on, the relay energizes for four seconds, then de-energizes
- when a detector is removed from a base with the power on, the relay is de-energized
- when the detector enters the alarm state, the relay is energized.

Isolator Base SIGA-IB, SIGA-IB4 - This base includes a built-in line fault isolator for use on Class A circuits. A detector must be installed for it to operate. The isolator base does not support the SIGA-LED Remote LED.

The isolator operates as follows:

- a short on the line causes all isolators to open within 23 msec
- at 10 msec intervals, beginning on one side of the Class A circuit nearest the loop controller, the isolators close to provide the next isolator down the line with power
- if the isolator next to the short closes, it reopens within 10 msec.

The process repeats beginning on the other side of the loop controller.

Remote LED SIGA-LED - The remote LED connects to the SIGA-SB or SIGA-SB4 Standard Base only. It features a North American size 1-gang plastic faceplate with a white finish and red alarm LED.

SIGA-TS4 Trim Skirt - Supplied with 4 inch bases, it can also be ordered separately to use with the other bases to help hide surface imperfections not covered by the smaller bases.

Warnings & Cautions

This detector will not operate without electrical power. As fires frequently cause power interruption, we suggest you discuss further safeguards with your fire protection specialist.

This detector will NOT sense fires that start in areas where heat cannot reach the detector. Heat from fires in walls, roofs, or on the opposite side of closed doors may not reach the detector to alarm it.

The heat sensor in this device only provides a source of information to supplement the information provided by photoelectric or ionization smoke detectors which may be located nearby. The heat detector by itself does NOT provide life safety protection. Under no circumstances should heat detectors be relied on as the sole means of fire protection.

Compatibility

The SIGA-HFS and SIGA-HRS detectors are compatible only with GE Security's Signature Loop Controller.

Specifications

Catalog Number	SIGA-HFS	SIGA-HRS
Heat Sensing Element	Fixed Temperature	Fixed & Temperature/ Rate-of-Rise
Alarm Point	Alarms at 135°F (57°C) Ambient	Alarms at 135°F (57°C) Ambient or Temp. increase above 15°F (9°C) per min.
UL Listed Detector Spacing	70 feet (21.3 meters) center to center spacing	
Operating and Storage Environment	Operating Temp: 32°F to 100°F (0°C to 38°C) Storage Temp: -4°F to 140°F (-20°C to 60°C) Humidity: 0 to 93% RH, Non-Condensing	
Operating Voltage	15.2 to 19.95 Vdc (19 Vdc nominal)	
Operating Current	Quiescent: 45µA @ 19 V Alarm: 45µA @ 19V Emergency Stand-alone Alarm Mode: 18mA Pulse Current: 100 µA (100 msec)	
Construction & Finish	High Impact Engineering Polymer - White	
Compatible Mounting Bases	SIGA-SB Standard Base, SIGA-RB Relay Base, SIGA-IB Isolator Base, SIGA-AB4, SIGA-AB4G Audible Bases	
LED Operation	On-board Green LED - Flashes when polled On-board Red LED - Flashes when in alarm; Both LEDs - Glow steady when in alarm (stand-alone) Compatible Remote Red LED (model SIGA-LED) Flashes when in alarm	
Compatibility	Use With: SIGNATURE Loop Controller	
Address Requirements	Uses one device address	
Agency Listings	UL, ULC, MEA, CSFM	

Ordering Information

Catalog Number	Description	Ship Wt. lbs (kg)
SIGA-HFS	Intelligent Fixed Temperature Heat Detector - UL/ULC Listed	0.5 (0.23)
SIGA-HRS	Intelligent Fixed Temperature/Rate-of-Rise Heat Detector - UL/ULC Listed	

Accessories		
SIGA-SB	Detector Mounting Base	
SIGA-SB4	4-inch Detector Mounting Base c/w SIGA-TS Trim Skirt	
SIGA-RB	Detector Mounting Base w/Relay	0.2 (.09)
SIGA-RB4	4-inch Detector Mounting Base /w Relay c/w SIGA-TS Trim Skirt	
SIGA-IB	Detector Mounting Base w/Fault Isolator	
SIGA-IB4	4-inch Detector Mounting Base w/ Fault Isolator c/w SIGA-TS Trim Skirt	
SIGA-LED	Remote Alarm LED	
SIGA-AB4G	Audible (Sounder) Base	0.3 (0.15)
SIGA-TS4	Trim Skirt (supplied with 4-inch bases)	0.1 (.04)

U.S.
T 888-378-2329
F 866-503-3996

Canada
T 519 376 2430
F 519 376 7258

Asia
T 852 2907 8108
F 852 2142 5063

Australia
T 61 3 9259 4700
F 61 3 9259 4799

Europe
T 32 2 725 11 20
F 32 2 721 86 13

Latin America
T 305 593 4301
F 305 593 4300

www.gesecurity.com

© 2006 General Electric Company
All Rights Reserved

Signature Series is a Trademark
of GE Security.



imagination at work